

iGMR-based angular sensor for rotor
position detection within EC-motors

AMAA

06/2011

Weinberger Markus
AIM SC AE VI
Infineon Technologies Austria AG



Table of Contents

■ Introduction

■ High-integrated digital angle-sensor

■ Analog angle-sensor

■ Summary

iGMR angle sensor applications

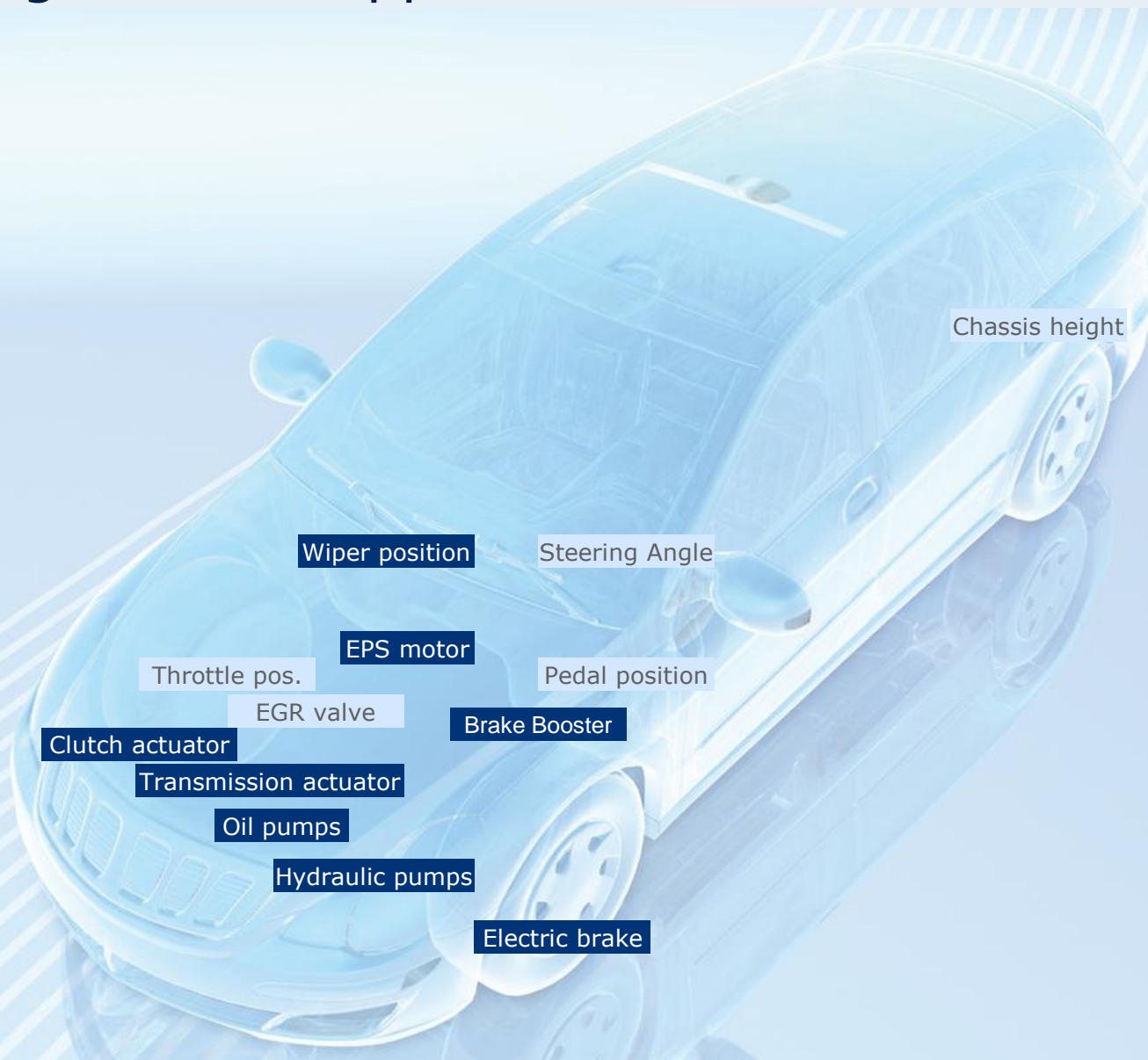

EC-Motor Set-up

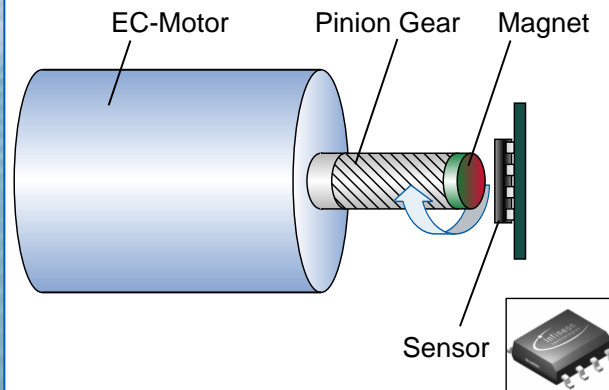
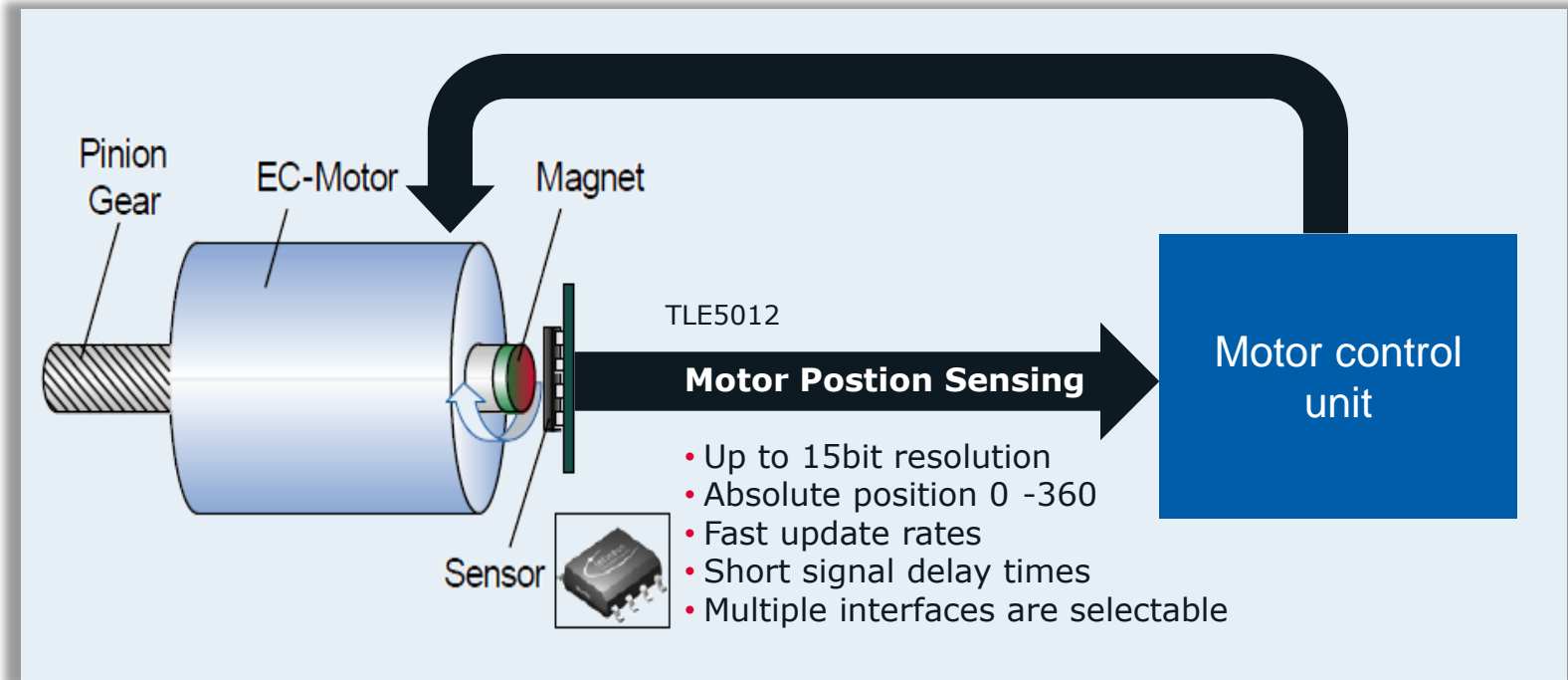

Table of Contents

■ Introduction

■ High-integrated digital angle-sensor

■ Analog angle-sensor

■ Summary

iGMR angle sensor basics

Spin-Valve

- Detected 1988 by Peter Grünberg / Albert Fert
- Quantum mechanical effect
- **Resistance** of spacer layer depends on external **Magnetic Field Direction**



- GMR is only sensitive to magnetic field direction
- Unambiguous 360° detection

$$\frac{\Delta R}{R}(\Theta_{m1m2}) = \left(\frac{\Delta R}{R}\right)_{GMR} \cdot \frac{(1 - \cos\Theta_{m1m2})}{2}$$

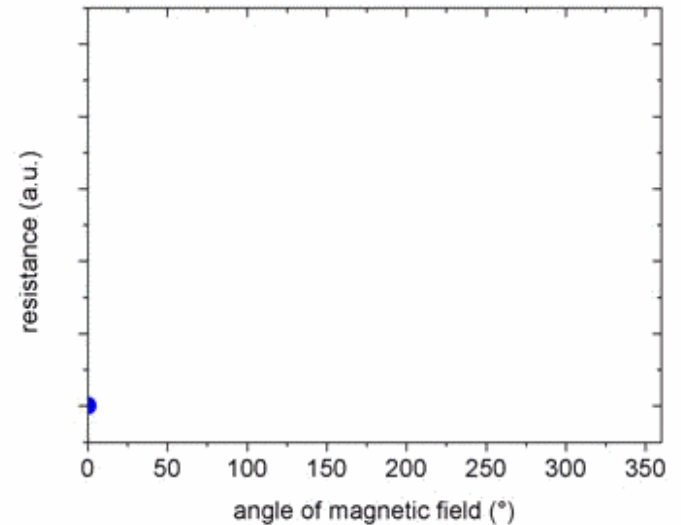
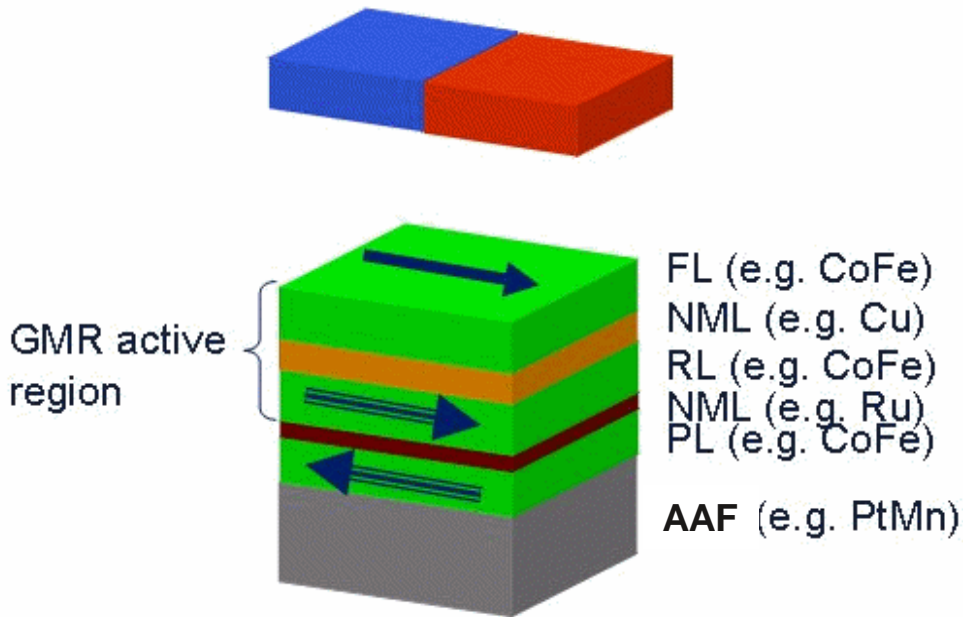

Infineon Integrated angle sensors

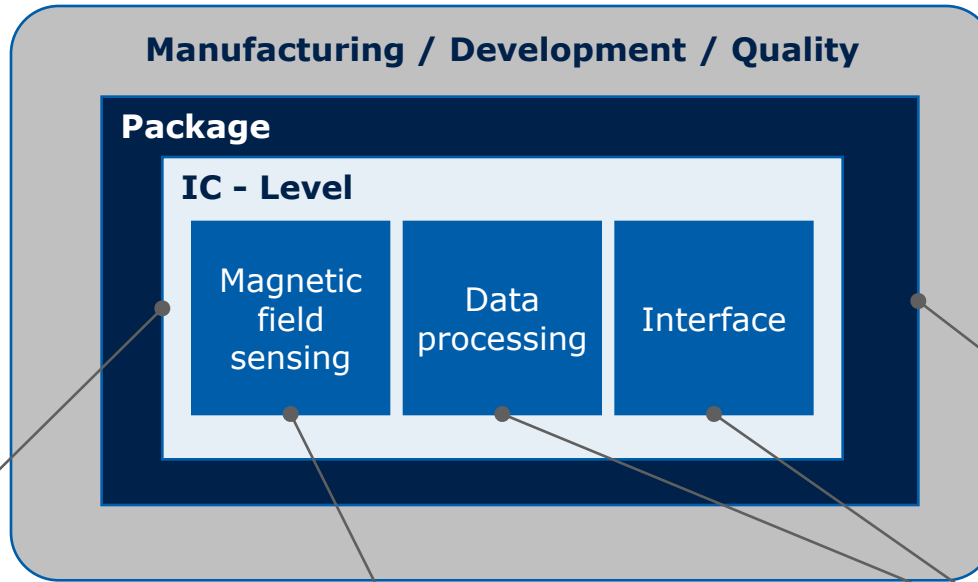

Package
PG-DSO-8 Package
Only 6mm x7mm outline dimensions
1,75mm max height
Lead free plating

Monolithic integration

- Sensor element and data processing IC in one piece of silicon.
- Small chip and package size
- Advanced self test capabilities

Sensing Element

Vertically integrated GMR bridge with direct vias to the active structures.

Small sensing element $\sim 600\mu\text{m}$ diameter of sensing area

Combination with standard wafer processes

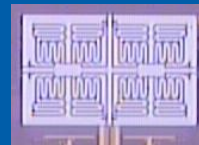

Standard technologies

Scalable data processing capabilities from basic signal conditioning to complex calculation, calibration and surveillance algorithms.

EEPROM also possible

Wide range of communication interfaces and I/O protection circuits can be realized

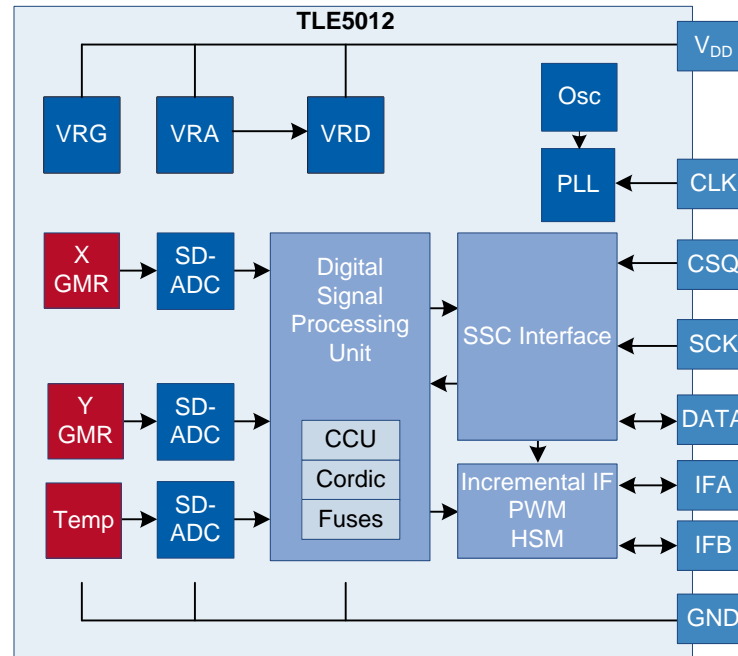

Hall Switch Mode

- emulation of 3 Hall switches for BLDC 6-step commutat.

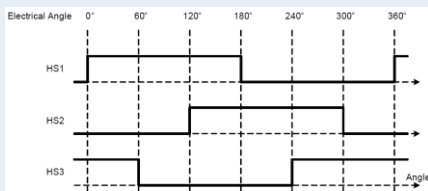

Incremental

- 3 channels A, B, and index Z

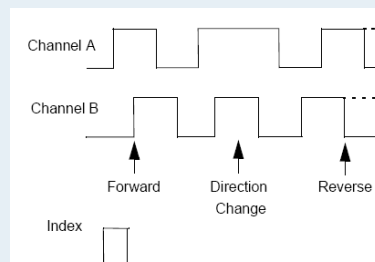

PWM

- from 12bit@250Hz to 12bit@2kHz

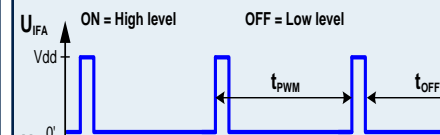

SPI Protocol

- 15bit absolute angle information
- 16bit sin/cos signal
- selectable update rate 21μs – 171μs



TLE5012 Delay

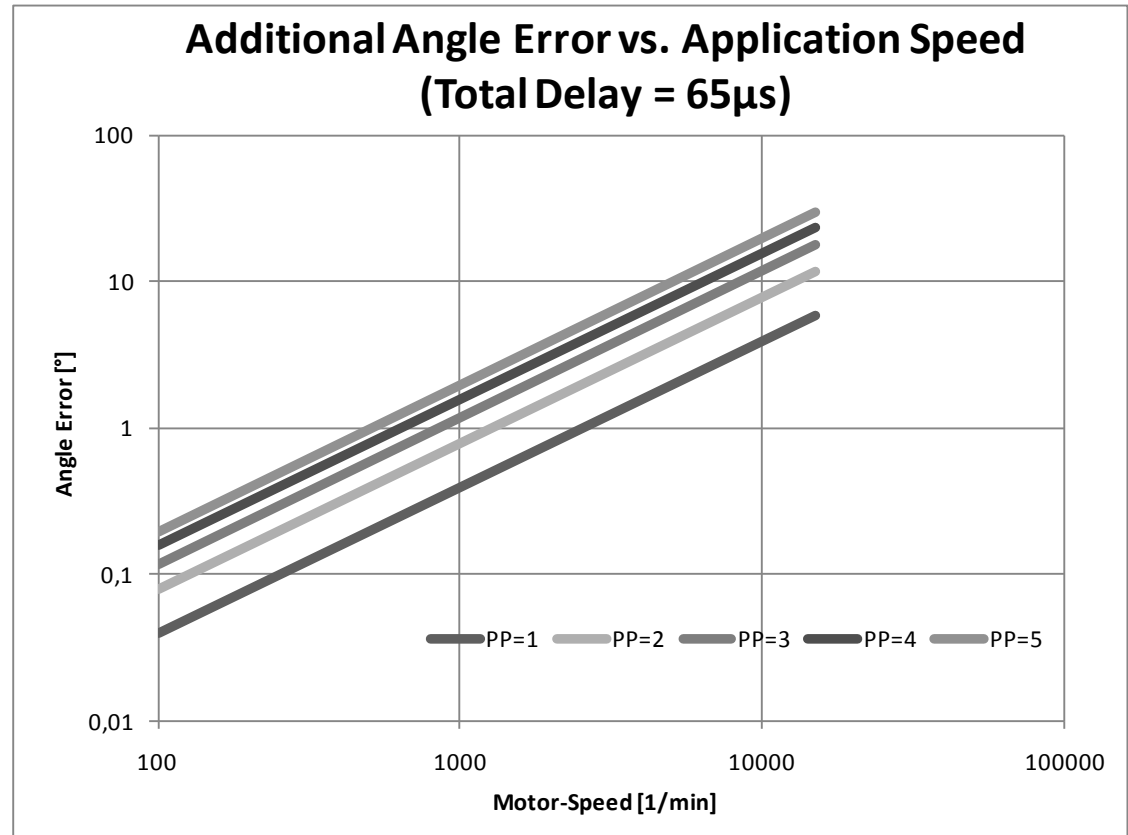
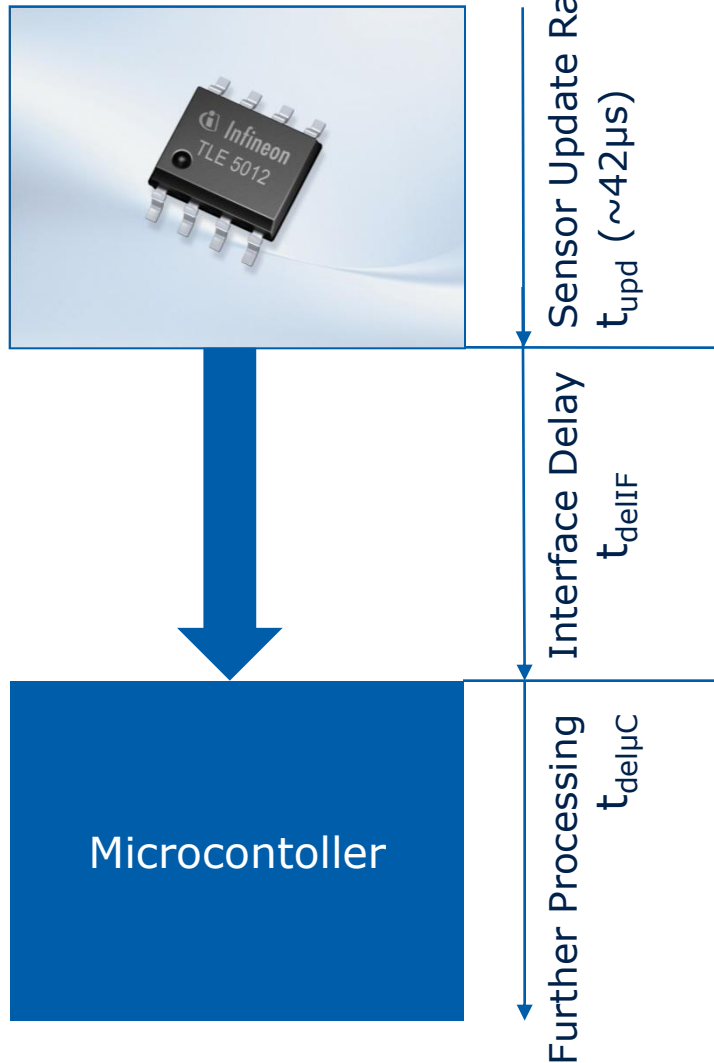

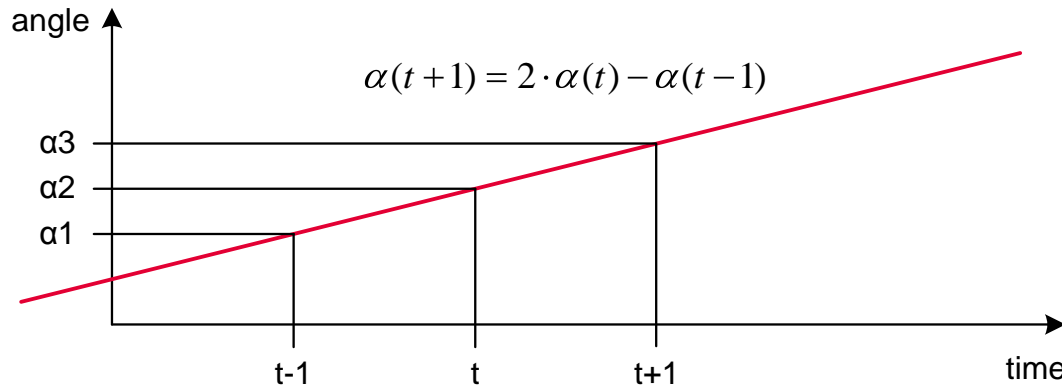
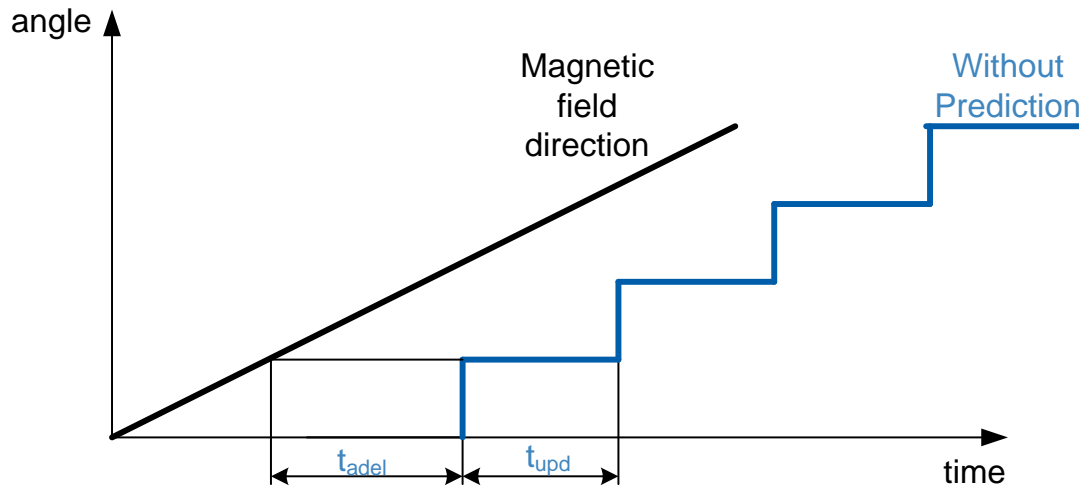

Comments

- Prediction reduces delay

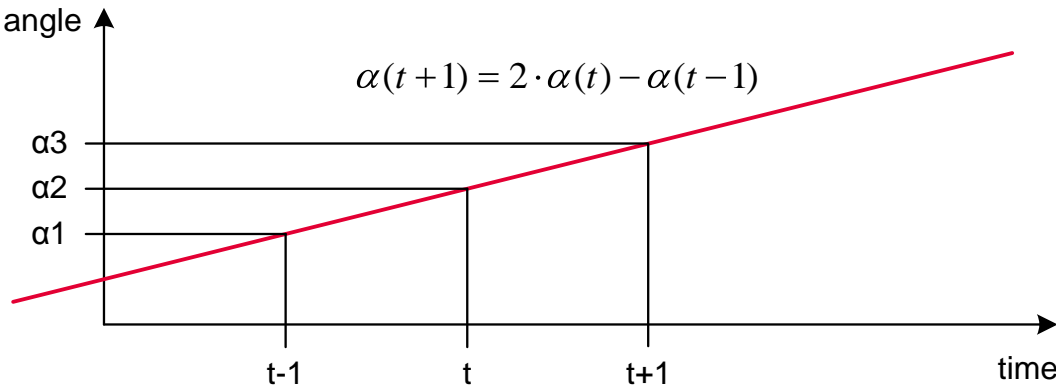
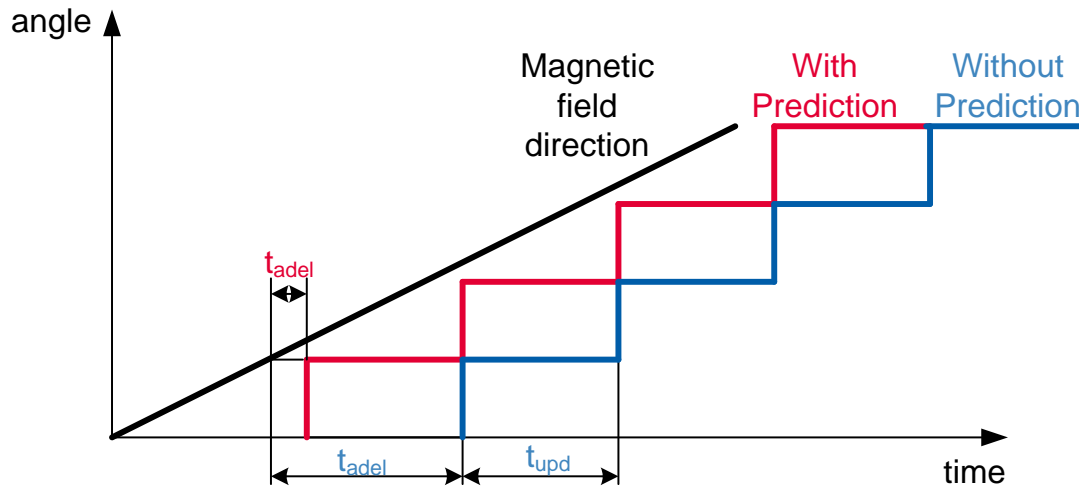

Comments

- Prediction reduces delay

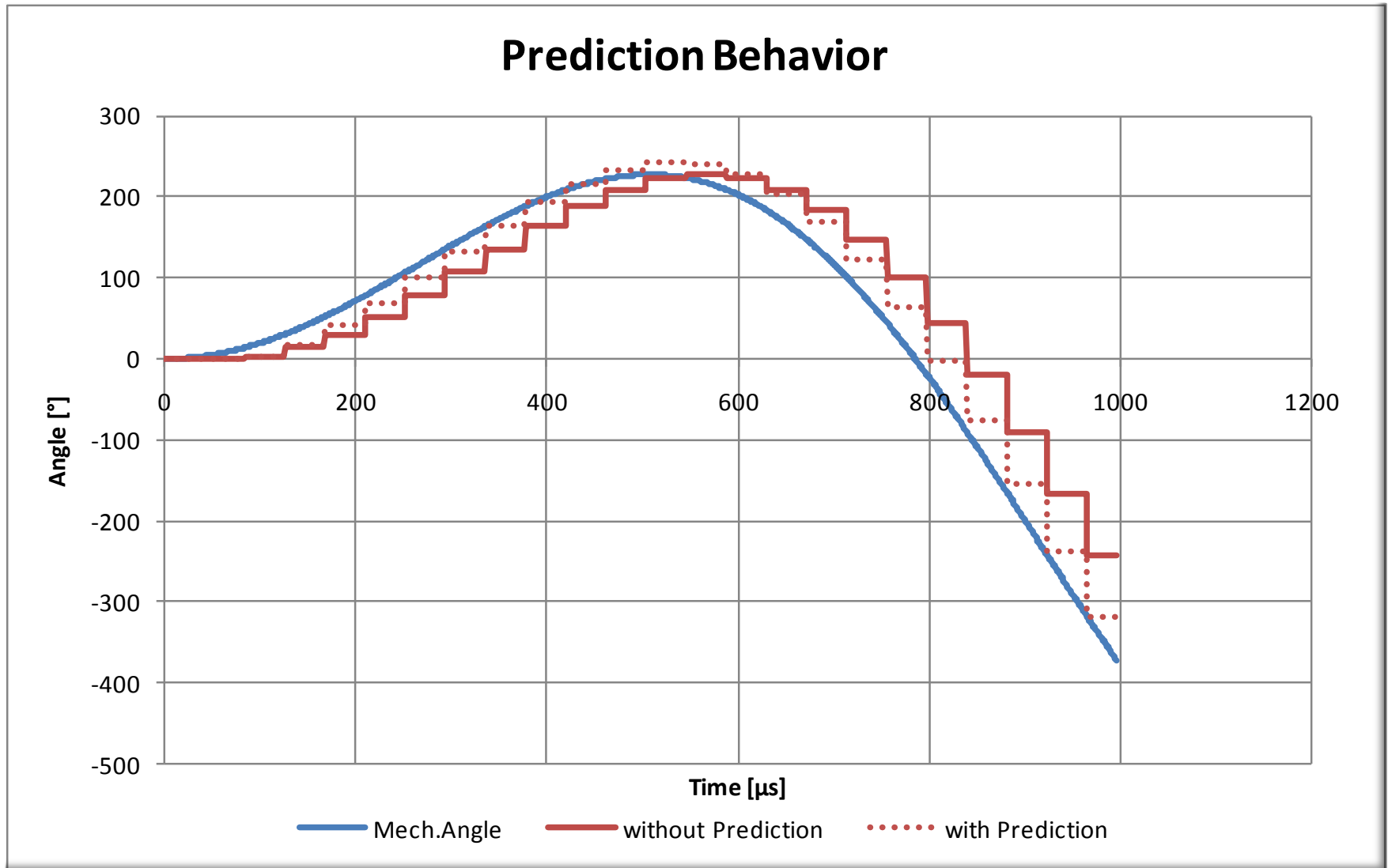

TLE5012 Synchronization

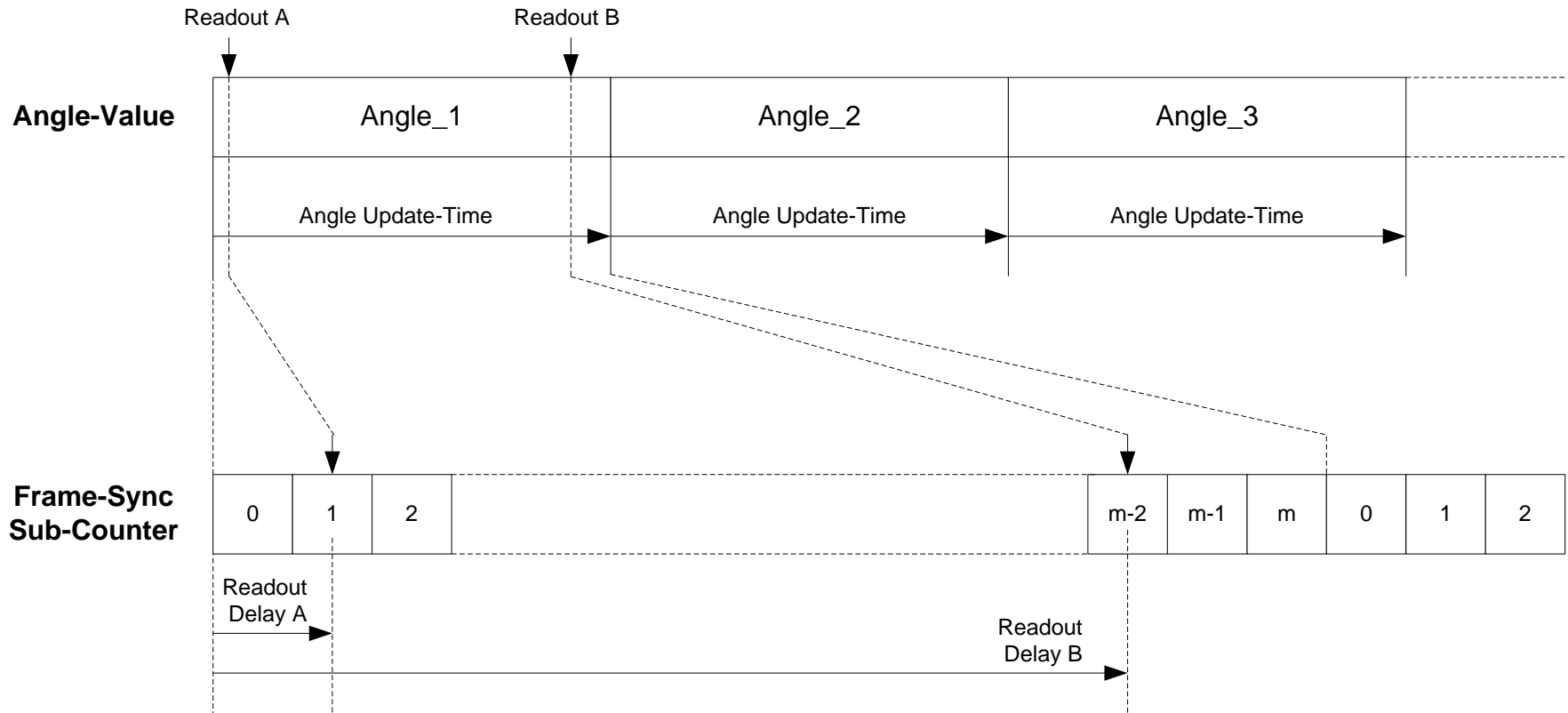

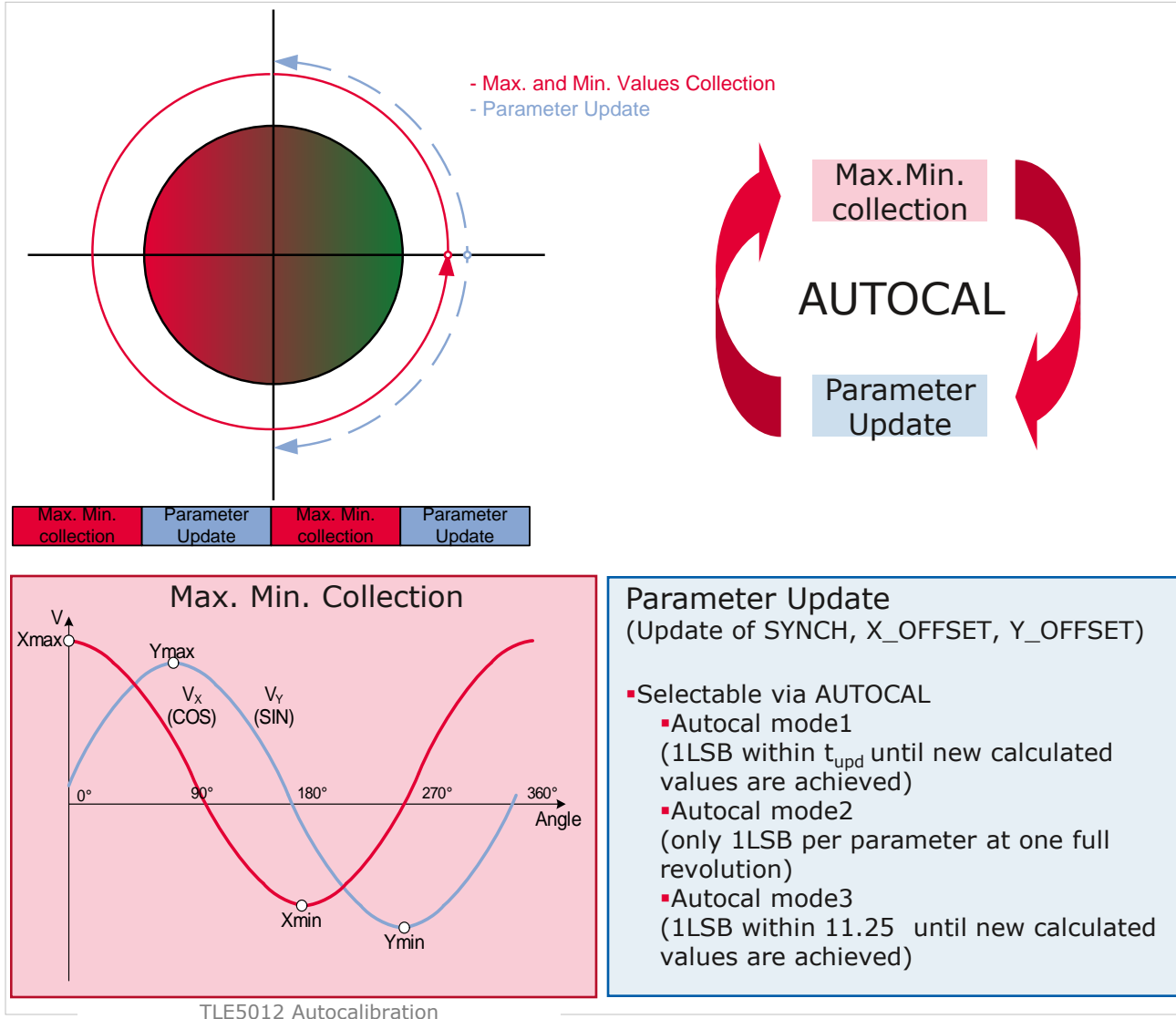

Comments

- Auto-calibration enables online parameter calculation
- Starts calculation after one full revolution
- Reduces angle errors due to misalignment, temperature drift and LT drift
- Angle error ≤ 1

- Example only for X_OFFSET with Autocal Angel mode3
 - fused X_OFFSET = 420
 - Start of Max. Min. Collection
 - After more than 360 new X_OFFSET = 425
 - Difference of 5 LSB; Update finished after 56.25 (5*11,25)

TLE5012

Auto-calibrations example

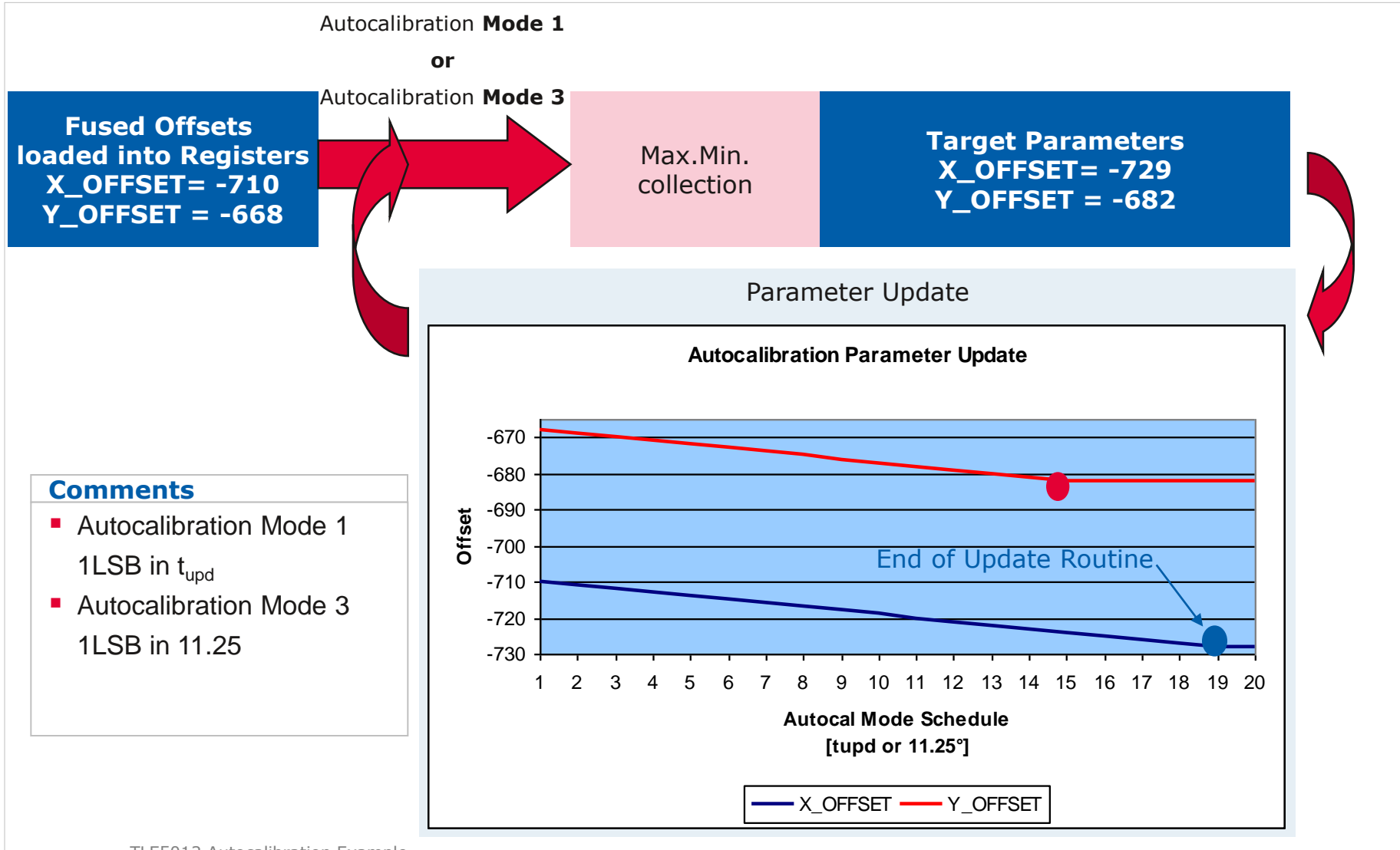

Angle Error

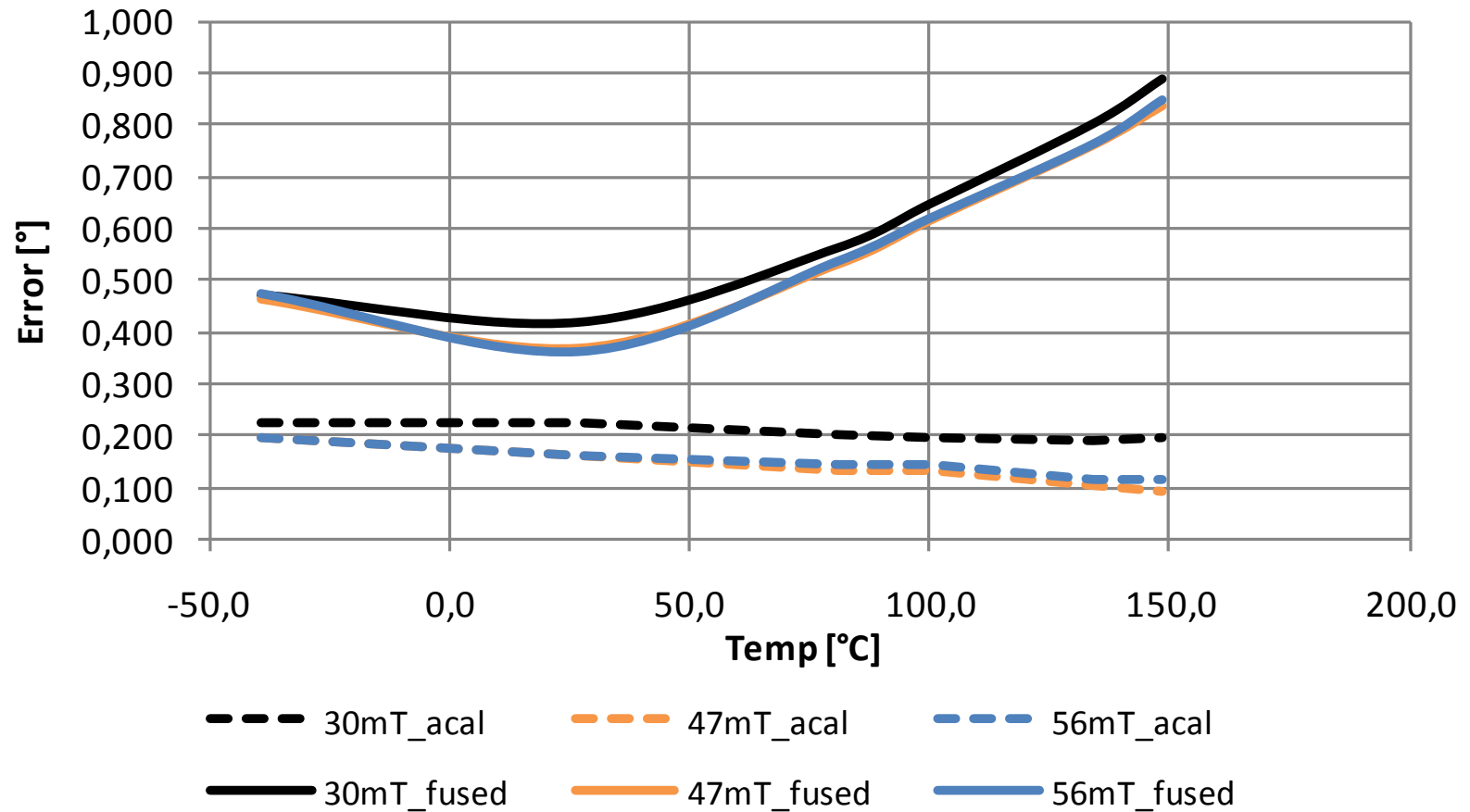

Table of Contents

■ Introduction

■ High-integrated digital angle-sensor

■ Analog angle-sensor

■ Summary

TLE5009 iGMR angle sensor



Key Features

- Giant Magneto Resistance (GMR)-based principle
- 360° contactless angle measurement
- Compensated and pre-amplified output signals
- Automotive qualified: -40 °C to 150 °C (junction temperature)
- Green package with lead-free (Pb-free) plating



iGMR

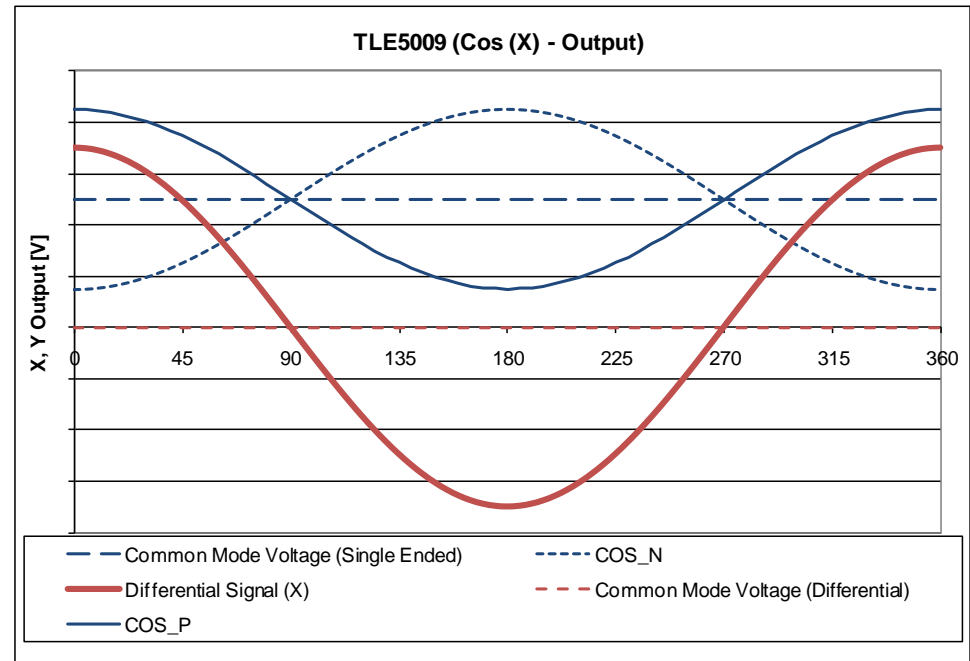
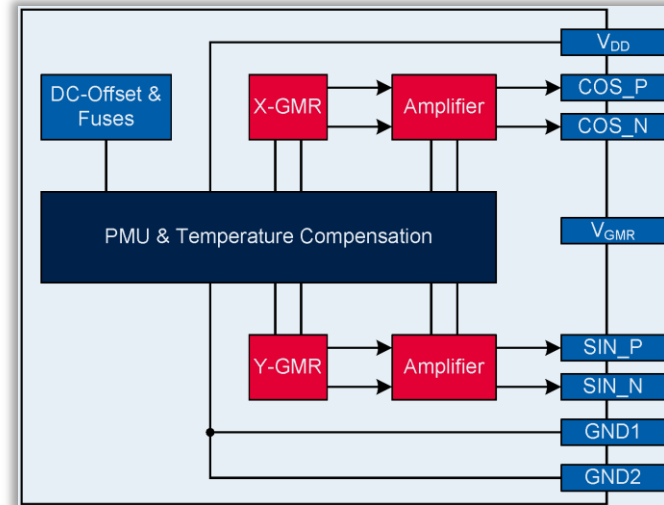

TLE5009

Angle error (calibrated at RT)

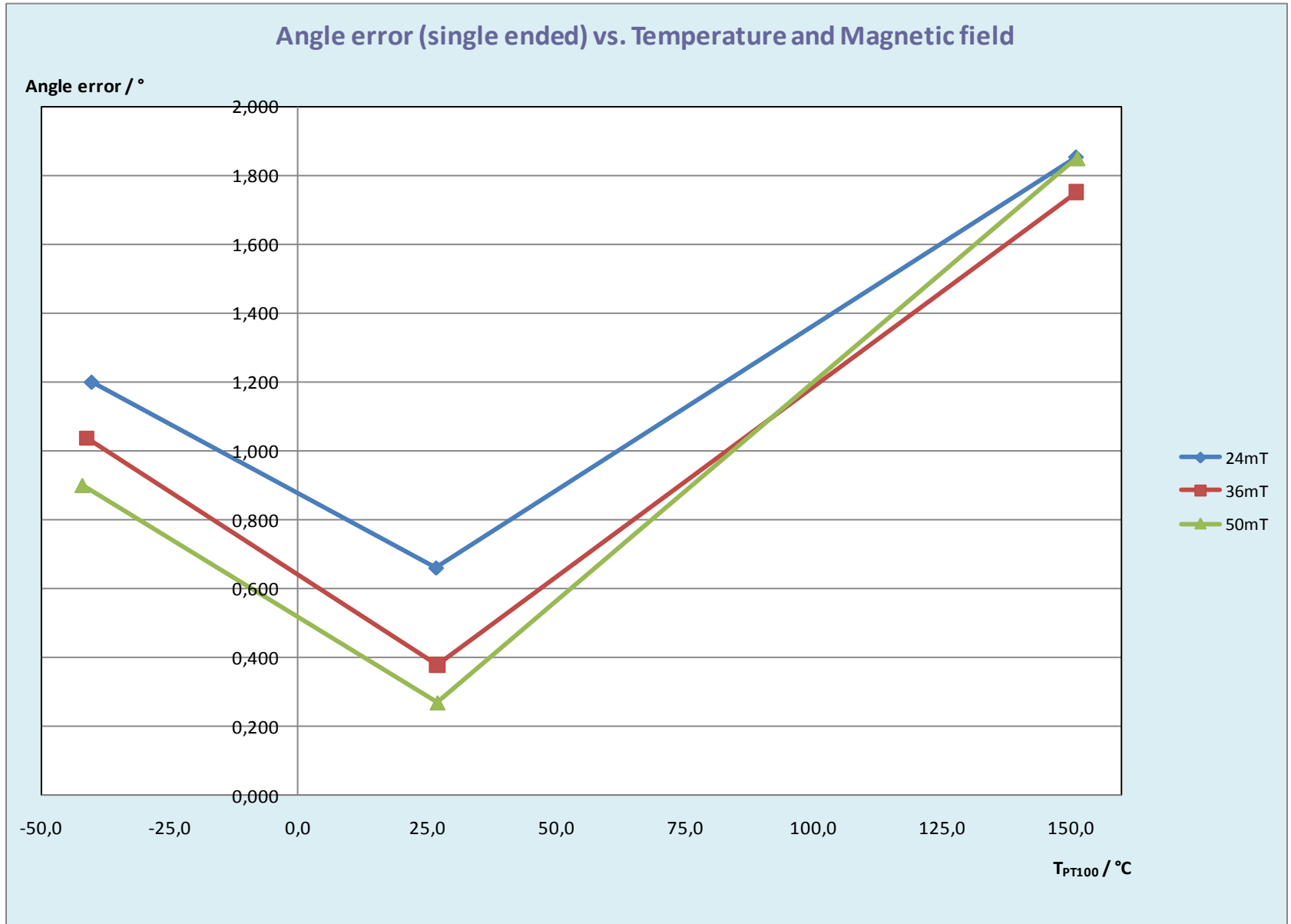

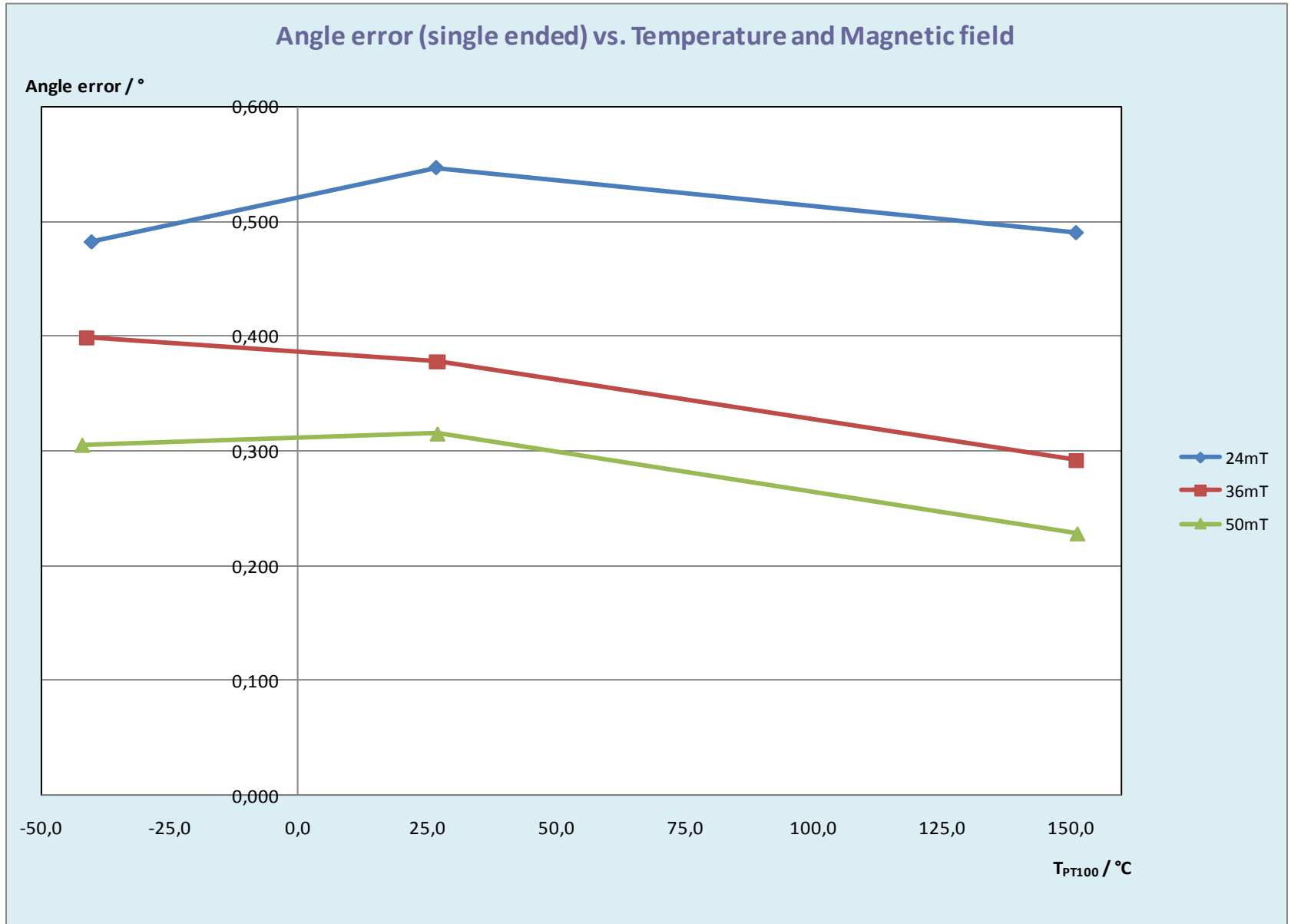

Table of Contents

■ Introduction

■ High-integrated digital angle-sensor

■ Analog angle-sensor

■ Summary

Summary

- Depending on system setup, different sensors are available.
- iGMR angle sensors deliver after power-on the absolute angle position of the rotor → Higher efficiency within commutation.
- TLE5012 and also TLE5009 are perfect suited for electrical commutated motors.
 - High Update Rate
 - Fast/parallel Interfaces
 - Autocalibration Algorithm (implemented within TLE5012)
 - Prediction (implemented within TLE5012)
- Sensors have already integrated safety features to support ASIL (ISO26262)
- Additional external parts can be reduced by monolithic integration → reduced costs



ENERGY EFFICIENCY MOBILITY SECURITY

Innovative semiconductor solutions for energy efficiency, mobility and security.

